

INTRODUCTION

Sauer-Danfoss a world leader in hydraulic power systems has developed a family of axial piston pumps.

DESCRIPTION

Sauer-Danfoss axial piston variable displacement pumps are of swash plate design with variable flow capability suitable for hydrostatic transmissions with closed loop circuit. Tilting the swash plate to the opposite side of the neutral or zero displacement position reverses flow direction.

Sauer-Danfoss axial piston variable displacement pumps are well engineered and easy to handle.

The full-length shaft with a highly efficient tapered roller bearing arrangement offers a high loading capacity for external radical forces.

The hydro-mechanical servo displacement control maintains the selected swash plate position and hence pumps displacement.

Upon release of the control handle, the swash plate automatically returns to zero position and the flow reduces to zero.

High case pressures can be achieved without leakage even at the lowest temperatures by using suitable shaft seals.

The servo valve arrangement offers the facility to incorporate function regulators and remote control systems.

Axial piston units are designed for easy servicing. Complete dismantling and reassembly can be carried out with standard hand tools, and all components or sub-assemblies are replaceable.

Axial piston variable displacement pumps of the Sauer-Danfoss pattern are made by licensed producers worldwide, providing consistent service and fully interchangeable parts.

TYPICAL MARKETS

- Industrial
- Mining
- Transit Mixer
- Utility Vehicles

© 2003 Sauer-Danfoss. All rights reserved.

Sauer-Danfoss accepts no responsibility for possible errors in catalogs, brochures and other printed material. Sauer-Danfoss reserves the right to alter its products without prior notice. This also applies to products already ordered provided that such alterations aren't in conflict with agreed specifications. All trademarks in this material are properties of their respective owners. Sauer-Danfoss and the Sauer-Danfoss logotype are trademarks of the Sauer-Danfoss Group.

Front cover illustrations: F005 104, F000 248, F000 150, F000 249

GENERAL DESCRIPTION	Introduction	2
	Description	2
	Typical markets	2
SECTIONAL VIEW	Axial piston variable displacement pump.....	4
SYSTEM CIRCUIT DESCRIPTION	Pump and motor circuit description	5
	Pump circuit schematic.....	5
TECHNICAL SPECIFICATION	Technical parameters.....	6
	Design	6
	Type of mounting	6
	Pipe connections	6
	Direction of rotation	6
	Installation position	6
	External drain fluid loss	6
	Hydraulic parameters.....	7
	System pressure range, input p_1	7
	System pressure range, output p_2	7
	Case pressure	7
	Hydraulic fluid.....	7
	Hydraulic fluid temperature range.....	7
	Viscosity range.....	7
	Filtration.....	7
	Shaft load.....	7
	Determination of nominal pump size	8
	Servo displacement control (linear response).....	9
	Pump flow direction	9
	Reversing time	10
	Reset time.....	11
Changing reversing and reset time.....	11	
DIMENSIONS – FRAME SIZE 070 AND 089	Outline drawing, configuration PS, displacement control VML 1.....	12
	Tapered shaft end	15
	Pump configuration AA 010, displacement control VML 1	15
DIMENSIONS – FRAME SIZE 334	Pump configuration PS, displacement control VML 1	17
	Pump configuration AA 010, displacement control VML 1	19

AXIAL PISTON VARIABLE DISPLACEMENT PUMP

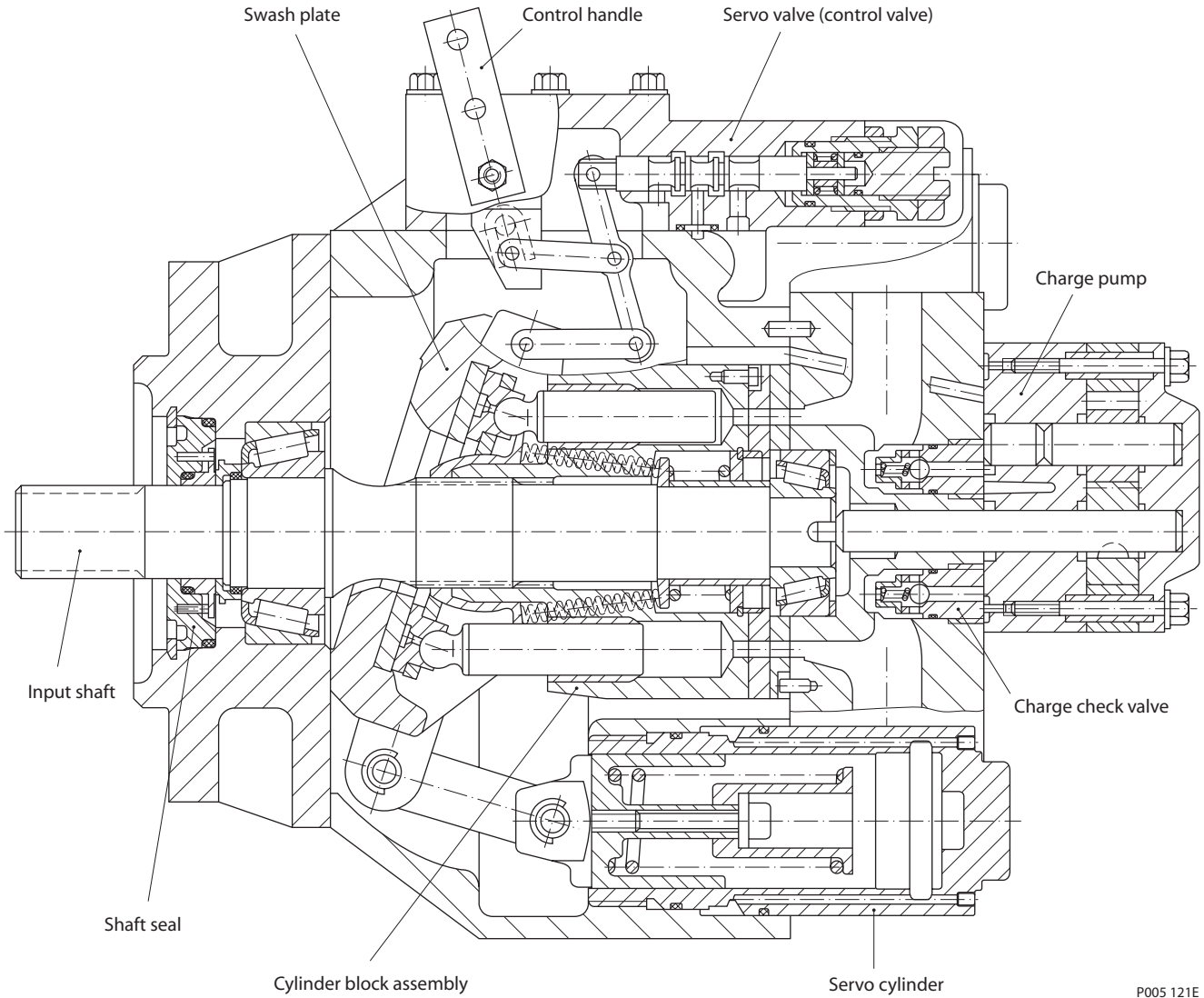

P005 121E

PUMP AND MOTOR CIRCUIT DESCRIPTION

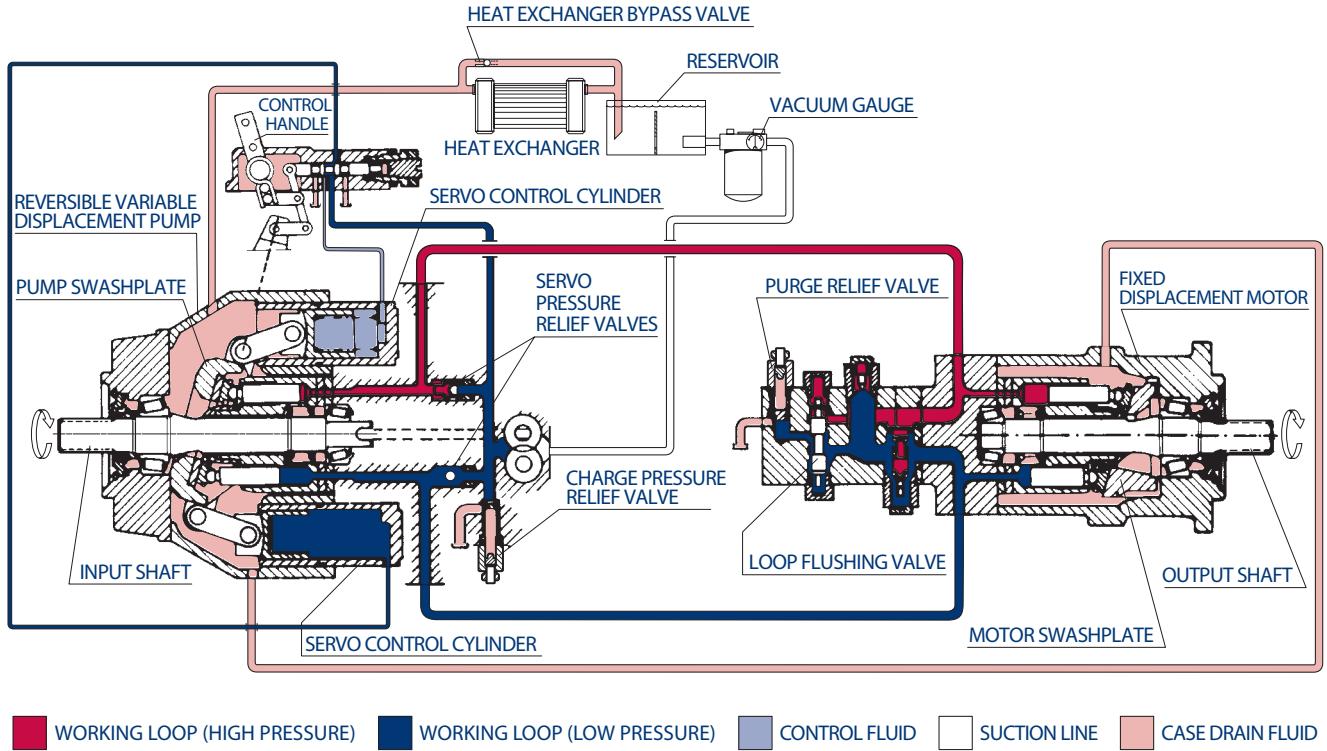

P000 027E

Above figure shows schematically the function of a hydrostatic transmission using an axial piston variable displacement pump and a fixed displacement motor.

PUMP CIRCUIT SCHEMATIC

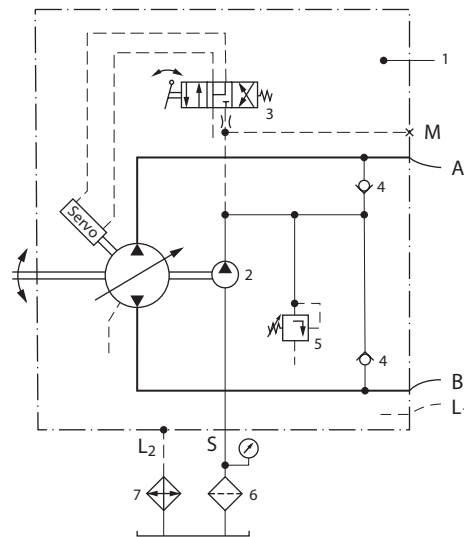

P000 012

Designation:

- 1 = Variable displacement pump
- 2 = Charge pump
- 3 = Servo control valve
- 4 = Charge check valve
- 5 = Charge relief valve
- 6 = Filter
- 7 = Heat exchanger

Ports:

- A, B = Main pressure ports (working loop)
- S = Suction port - charge pump
- L1, L2 = Drain ports
- M = Gauge port - charge pressure

TECHNICAL PARAMETERS

Design

Axial piston pump of swash plate design, with variable displacement.

Type of mounting

SAE four bolt flanges.

Pipe connections

Main pressure ports: SAE split flange

Remaining ports: SAE O-ring boss

Direction of rotation

Clockwise or counterclockwise (viewing from the input shaft).

Installation position

Optional; pump housing must be always filled with hydraulic fluid.

External drain fluid loss

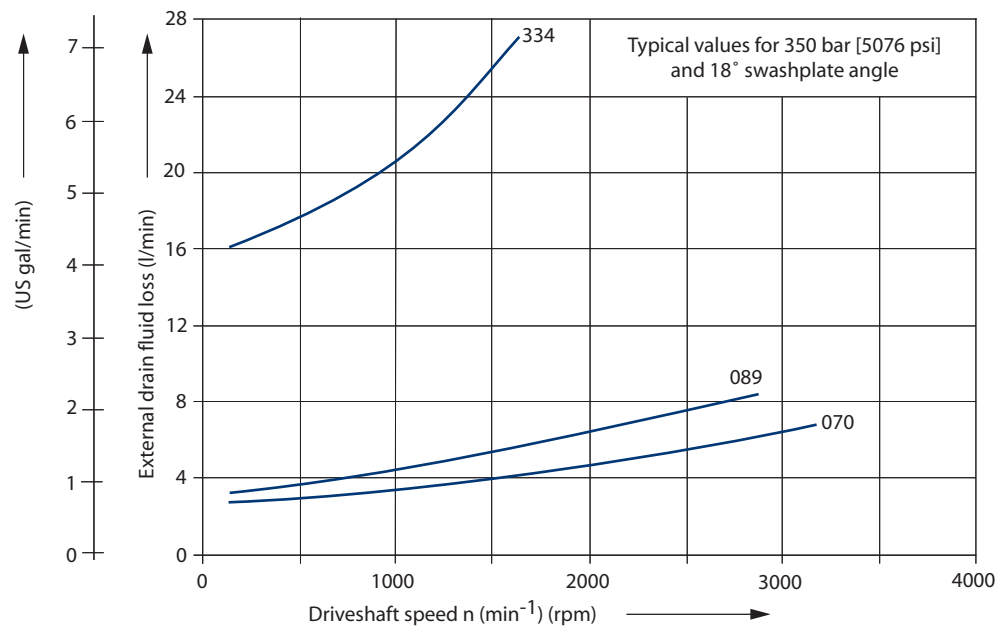

P005 105E

HYDRAULIC PARAMETERS

System pressure range, input p_1

Variable displacement pump:

Charge pressure nominal: 13 bar [189 psi] above case pressure

Charge pressure minimum: 8 bar [116 psi], intermittent only

Charge pump input pressure:

Min. allowable pressure, continuous = 0.75 bar [10.9 psi] absolute

Min. allowable pressure, intermittent = 0.50 bar [7.3 psi] absolute (for cold start)

Charge pump output pressure:

Max. operating pressure = 35 bar [508 psi] above case pressure

System pressure range, output p_2

Pressure on port A or B: Max. operating pressure $\Delta p = 420$ bar [6092 psi]

Max. high pressure setting $\Delta p = 460$ bar¹ [6672 psi]

¹only with POR-valve

Case pressure

Max. rated pressure = 2.5 bar [36.3 psi]

Intermittent = 5.0 bar [72.5 psi]

Hydraulic fluid

Refer to Sauer-Danfoss publications *Hydraulic Fluids and Lubricants* and *Experience with Bio Fluids for biodegradable hydraulic fluids*.

Hydraulic fluid temperature range

$\vartheta_{\min} = -40$ °C [-40 °F]

$\vartheta_{\max} = 95$ °C [203 °F]

Viscosity range

$v_{\min} = 7$ mm²/s [49 SUS*]

$v_{\max} = 1000$ mm²/s [4630 SUS*] (intermittent cold start)

Recommended viscosity range: 12 - 60 mm²/s [66 - 280 SUS*]

*SUS (Saybolt Universal Second)

Filtration

Required cleanliness level: ISO 4406 - 1999 Code 22/18/13 or better. Refer to Sauer-Danfoss publication *Hydraulic Fluids and Lubricants* and *Design Guideline for Hydraulic Fluid Cleanliness*.

Shaft load

The pump will accept radial and axial loads on its shaft, the maximum capacity being determined by direction and point of application of the load.

Please contact your Sauer-Danfoss representative.

**HYDRAULIC
 PARAMETERS
 (continued)**

Technical data

			Frame size		
			070	089	334
Max. displacement		cm ³ [in ³]	69.8 [4.26]	89.0 [5.43]	333.7 [20.36]
Charge pump displacement	options	cm ³ [in ³]	18.03 [1.10]		65.50 [4.00]
			12.30 [0.75]		–
Minimum speed		min ⁻¹ (rpm)	500		
Rated speed 1		min ⁻¹ (rpm)	3200	2900	1900
Maximum swash plate angle		degree	±18		
Mass moment of inertia of rotating group (without charge pump)		kg m ² · 10 ⁻³ [lbf ft ² · 10 ⁻³]	12.34 [292.8]	17.77 [421.7]	161.40 [3830.0]
Weight		kg [lb]	63 [139]	78 [172]	270 [595]

¹ for higher speeds contact your Sauer–Danfoss representative

Determination of nominal pump size

Unit:	Metric system:	Inch system
Pump output flow	$Q = \frac{V_g \cdot n \cdot \eta_v}{1000}$ l/min	$Q = \frac{V_g \cdot n \cdot \eta_v}{231}$ [gpm]
Input torque	$M = \frac{V_g \cdot \Delta p}{20 \cdot \pi \cdot \eta_m}$ Nm	$M = \frac{V_g \cdot \Delta p}{2 \cdot \pi \cdot \eta_m}$ [lbf·in]
Input power	$P = \frac{V_g \cdot n \cdot \Delta p}{600\,000 \cdot \eta_t}$ kW	$P = \frac{V_g \cdot n \cdot \Delta p}{396\,000 \cdot \eta_t}$ [hp]

Efficiency characteristic curves available on request.

V_g	= Pump displacement per revolution	cm ³ [in ³]
n	= Pump speed	min ⁻¹ (rpm)
Δp	= Hydraulic pressure differential	bar [psid]
	$\Delta p = p_{HD} - p_{ND}$	
η_v	= Pump volumetric efficiency	
η_m	= Pump mechanical efficiency	
η_t	= Pump total efficiency	
p_{HD}	= High pressure	bar [psid]
p_{ND}	= Low pressure	bar [psid]

SERVO DISPLACEMENT CONTROL (LINEAR RESPONSE)

Regulated by the control handle on the servo valve, the swash plate can be infinitely varied in both directions with the help of the servo system. The pump displacement resulting from any control handle position can be established using the figures on this page. The angle of the control handle for stroke initiation and for the final position of the stroke can vary from unit to unit within the range of the tolerance band. The inter-relationship of flow direction, rotation of the pump and the control handle movement is shown below.

Pump flow direction

Flow direction changes with the direction of rotation and the control handle movement (see *above*).

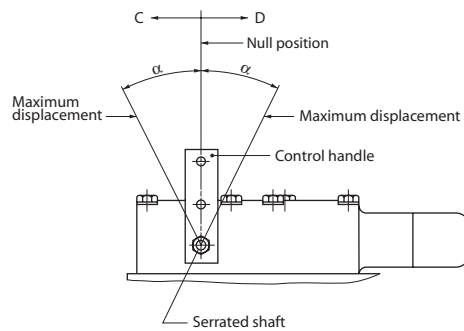

Pump rotation	Movement of control handle in direction	Pressure port OUT	Pressure port IN
Counterclockwise (L)	C	B	A
	D	A	B
Clockwise (R)	C	A	B
	D	B	A

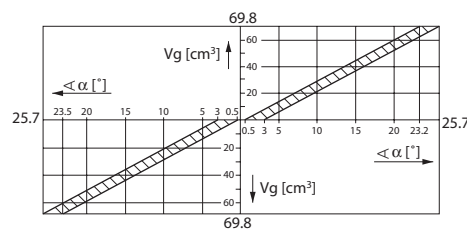

SPV 2/070

P000 016

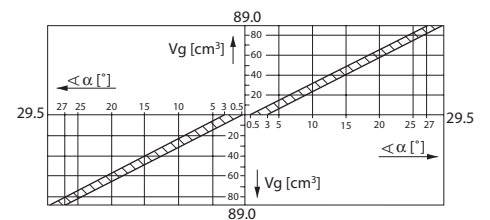

SPV 2/089

P000 017

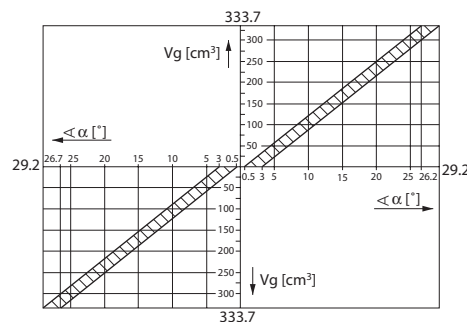

SPV 2/334

P000 021

**SERVO DISPLACEMENT
 CONTROL
 (LINEAR RESPONSE)
 (continued)**

Reversing time

Time for the directional change of the flow from Q_{max} , across zero to Q_{max} , depending on the size of the control orifice fitted in the supply port to the servo valve (see *below*). The values given assume movement of the control handle directly from one end position to the other.

Adjustment time of handle: < minimum reserving time

Operating pressure: $\Delta p_2 = 210 \text{ bar [3046 psi]}$

Speed: $n = 1450 \text{ min}^{-1} \text{ (rpm)}$

System temperature: $50 \text{ }^\circ\text{C [122 }^\circ\text{F]}$

Viscosity: $35 \text{ mm}^2/\text{s [164 SUS]}$

Frame size	Minimum reversing time (s) without orifice	Maximum reversing time (s) with orifice $\varnothing 0.66$ in supply port
070	1.0	9.3
089	1.1	9.0
334	5.6	43.8

Schematic diagram of servo valve with alternative orifice positions

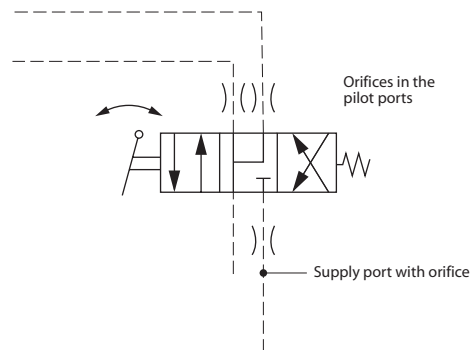

SERVO DISPLACEMENT CONTROL (LINEAR RESPONSE) (continued)

Reset time

Time for reducing the flow from either flow direction from Q_{max} to 0 releasing the control handle.

Assuming no mechanical blockage of the control handle's free return and assuming no orifices in the pilot ports:

Operating pressure: $\Delta p_2 = 210 \text{ bar [3046 psi]}$

System temperature: $50 \text{ }^\circ\text{C [122 }^\circ\text{ F]}$

Viscosity: $35 \text{ mm}^2/\text{s [164 SUS]}$

Frame size	Minimum reset time (s)
070	3.0
089	
334	5.4

Servo valve counter bored recesses for orifice insert

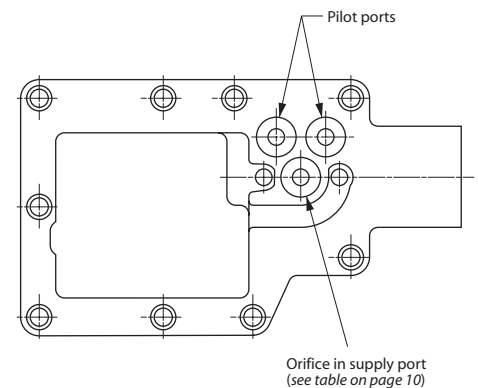

P000 057E

Changing reversing and reset time

Inserting one orifice in each of the pilot ports can extend the reversing time. The reset time will also be extended.

Inserting an orifice in one of the pilot ports only can extend the reversing time in one flow direction. The reset time will be extended only for this flow direction.

**OUTLINE DRAWING,
 CONFIGURATION
 PS, DISPLACEMENT
 CONTROL VML 1**

- * Minimum and maximum angle α , (see section *servo displacement control*).
- ** Shaft spline data: spline shaft with involute spline, according to SAE handbook, 1963, class 1, fillet root side fit.

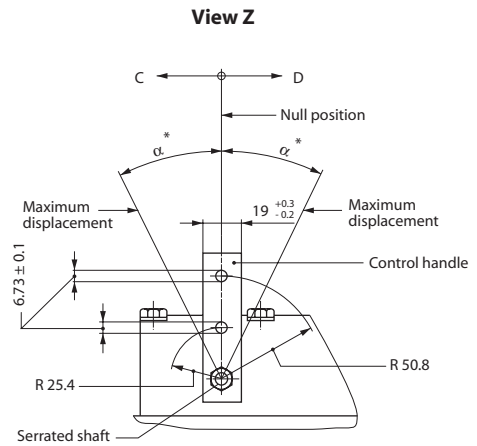

P000 022E

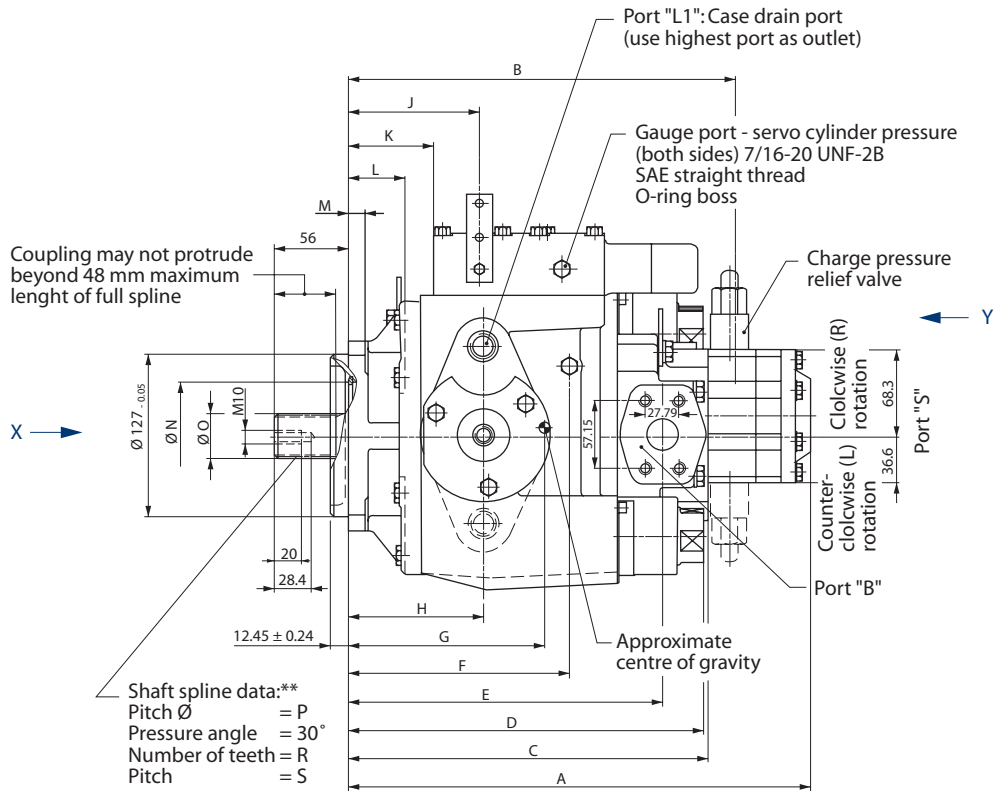

P005 106E

**OUTLINE DRAWING,
CONFIGURATION
PS, DISPLACEMENT
CONTROL VML 1
(continued)**

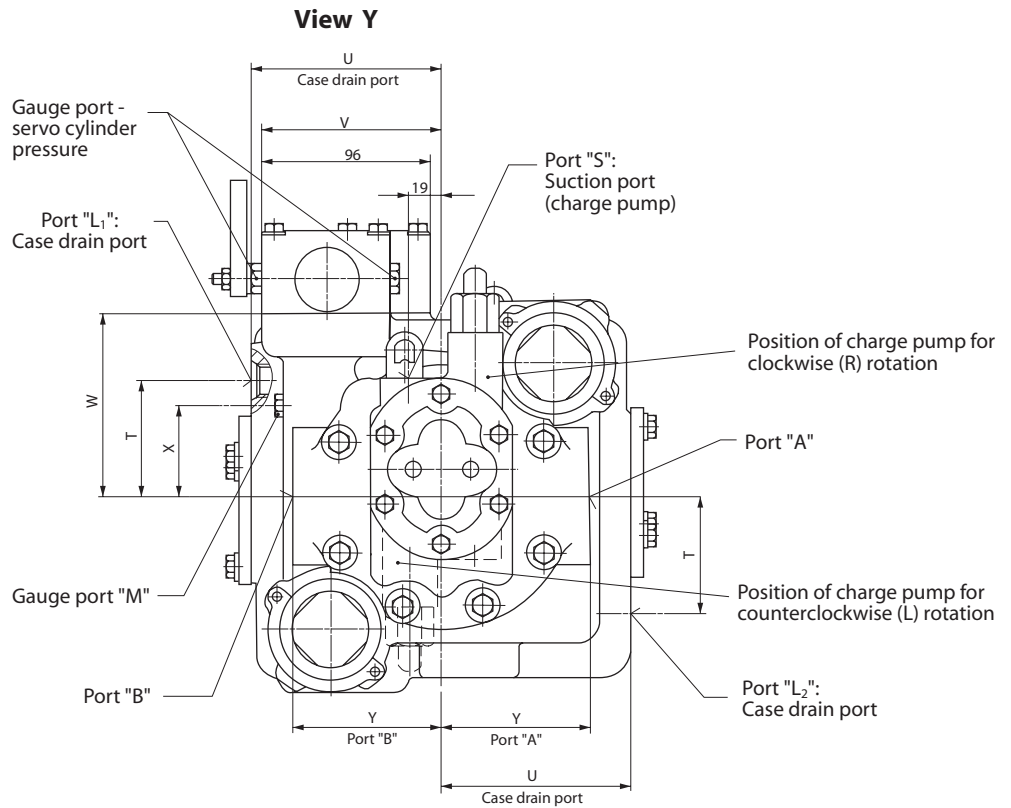

P005 107E

Max. torque for charge pump inlet port (7/8 -14 UNF - 2B) is 22 - 28 Nm [195 - 248 lbf·in].

Frame size	Port A and B	Port L ₁ and L ₂	Port S	Port M
070	SAE flange, size 1 SAE split flange boss 5000 psi 4 threads	7/8-14 UNF-2B SAE straight thread O-ring boss	7/16-20 UNF-2B SAE straight thread O-ring boss	7/16-20 UNF-2B SAE straight thread O-ring boss
089	3/8-16 UNC-2B 18 deep			

OUTLINE DRAWING, CONFIGURATION PS, DISPLACEMENT CONTROL VML 1 (continued)

View X (for SPV 2/070 only)

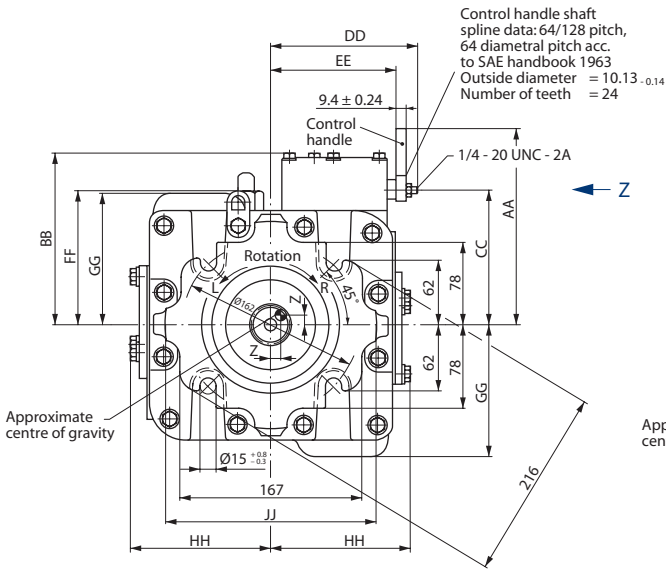

View X (for SPV 2/089 only)

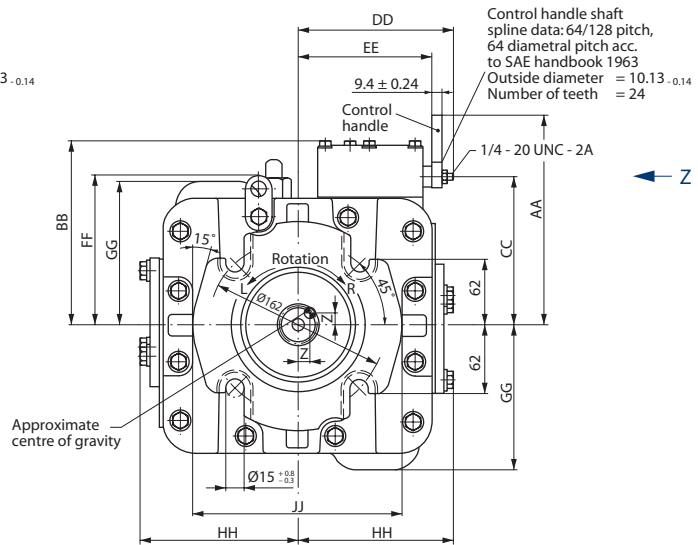

P005 108E

Dimensions

Frame size	B mm [in]	C mm [in]	D mm [in]	E mm [in]	F mm [in]	G mm [in]	H mm [in]	J mm [in]	K mm [in]	L mm [in]	M mm [in]	Ø N mm [in]
070	315 [12.402]	294 [11.575]	305 [12.008]	259 [10.197]	188 [7.402]	146 [5.748]	112 [4.409]	120 [4.724]	84 [3.307]	48 [1.890]	16 [0.630]	84 [3.307]
089	328 [12.913]	307 [12.087]	312 [12.283]	271 [10.669]	195 [7.677]	140 [5.512]	118 [4.646]	129 [5.079]	91 [3.583]	49 [1.929]	17.5 [0.689]	98 [3.858]
Frame size	T mm [in]	U mm [in]	V mm [in]	W mm [in]	X mm [in]	Y mm [in]	Z mm [in]	AA mm [in]	BB mm [in]	CC mm [in]	DD mm [in]	EE mm [in]
070	71.4 [2.811]	112.7 [4.437]	105 [4.134]	108 [4.252]	60.5 [2.382]	85.8 [3.378]	9.5 [0.374]	187.6 [7.386]	162 [6.378]	128.6 [5.063]	133 [5.236]	113 [4.449]
089	77.7 [3.059]	128.7 [5.067]	115 [4.528]	119 [4.685]	65 [2.559]	95.2 [3.748]	12.7 [0.500]	198.6 [7.819]	173 [6.811]	139.6 [5.496]	144 [5.669]	123 [4.843]
Frame size	FF mm [in]	GG mm [in]	HH mm [in]	JJ mm [in]	Charge pump		Shaft spline				Bore diameter for shaft coupling mm [in]	
					A ¹ mm [in]	cm ³ [in]	12 [0.732]	18 [1.098]	Ø O mm [in]	Ø P mm [in]		R mm [in]
070	126 [4.961]	123 [4.843]	130 [5.118]	194 [7.638]	372 [14.646]	381 [15.000]	34.50 ^{-0.17} [1.358 ^{-0.0067}]	33.338 [1.313]	21 [0.827]	16/32	31.75 ^{+0.062} [1.250 ^{+0.0024}]	
089	140 [5.512]	134 [5.276]	148 [5.827]	194 [7.638]	358 [14.094]	394 [15.512]	37.68 ^{-0.17} [1.483 ^{-0.0067}]	36.513 [1.438]	23 [0.906]	16/32	34.95 ^{+0.062} [1.376 ^{+0.0024}]	

¹ Short version available on request. Please contact your local Sauer-Danfoss representative.

TAPERED SHAFT END

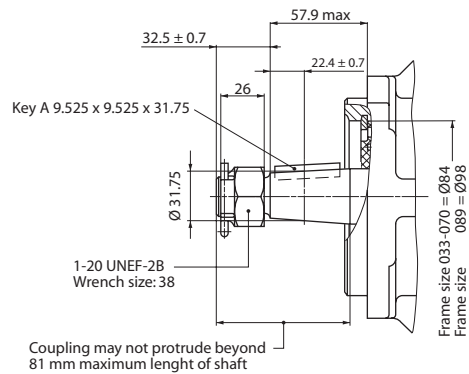

Depth, keygroove: 5,7 + 0,1
 Shaft, cone: 1 : 8

P000 006E

**PUMP CONFIGURATION
 AA 010, DISPLACEMENT
 CONTROL VML 1**

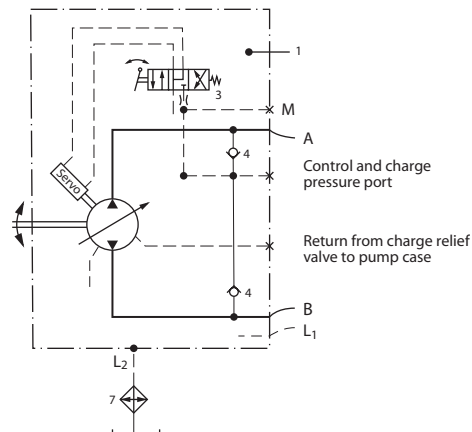

Designation:

- 1 = Variable Displacement pump
- 3 = Servo control valve
- 4 = Charge check valve
- 7 = Heat exchanger

Ports:

- A, B = Main pressure ports (working loop)
- L1, L2 = Drain ports
- M = Gauge port - charge pressure

P000 058E

PUMP CONFIGURATION AA 010, DISPLACEMENT CONTROL VML 1 (continued)

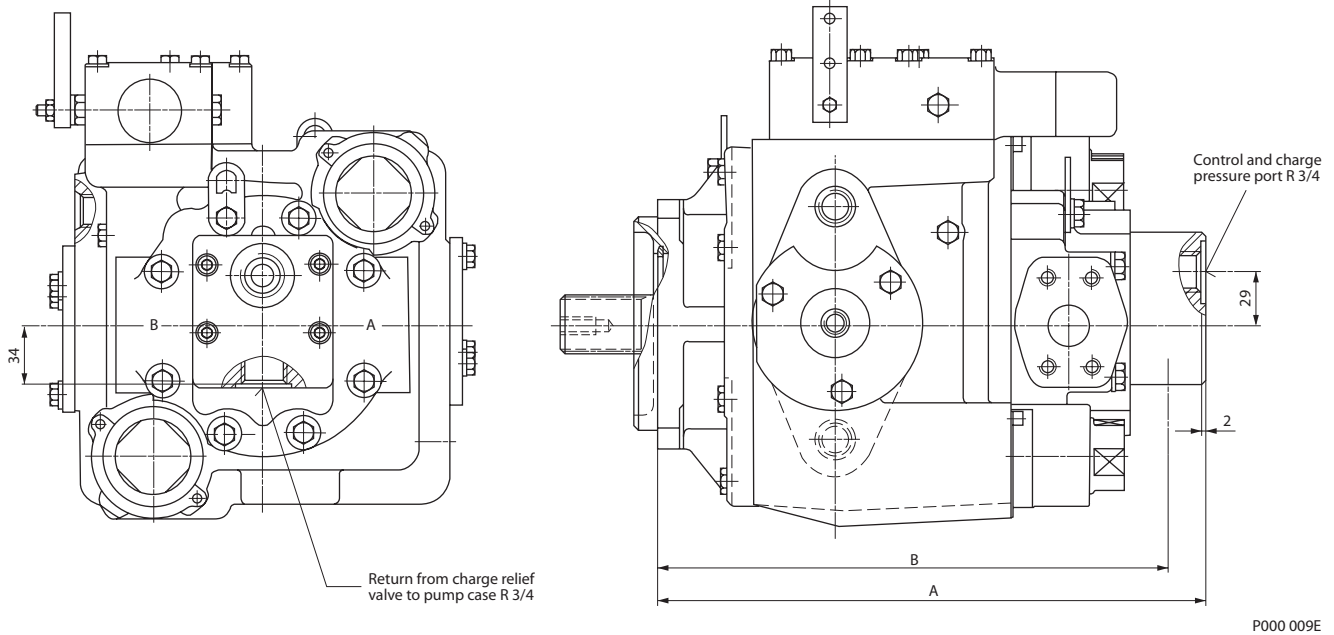

Dimensions

Frame Size	A mm [in]	B mm [in]	Weight kg [lb]
070	339 [13.346]	316 [12.441]	63.5 [140]
089	352 [13.858]	329 [12.953]	78.5 [173]

**PUMP CONFIGURATION
 PS, DISPLACEMENT
 CONTROL VML 1**

- * Minimum and maximum angle α , (see section *servo displacement control*).
- ** Shaft spline data: spline shaft with involute spline, according to SAE handbook, 1963, class 1, fillet root side fit.

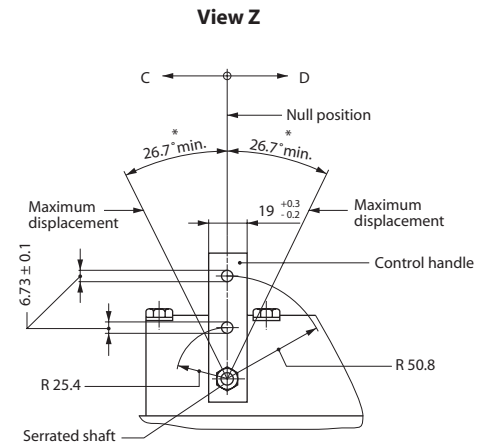

P000 026E

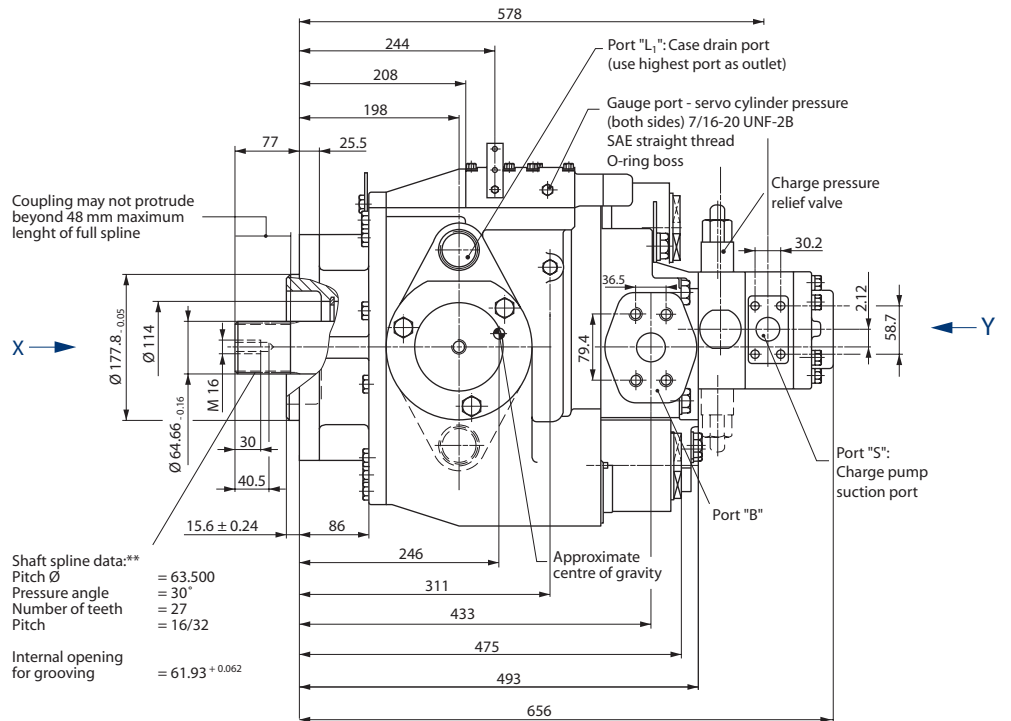

P005 115E

PUMP CONFIGURATION PS, DISPLACEMENT CONTROL VML 1 (continued)

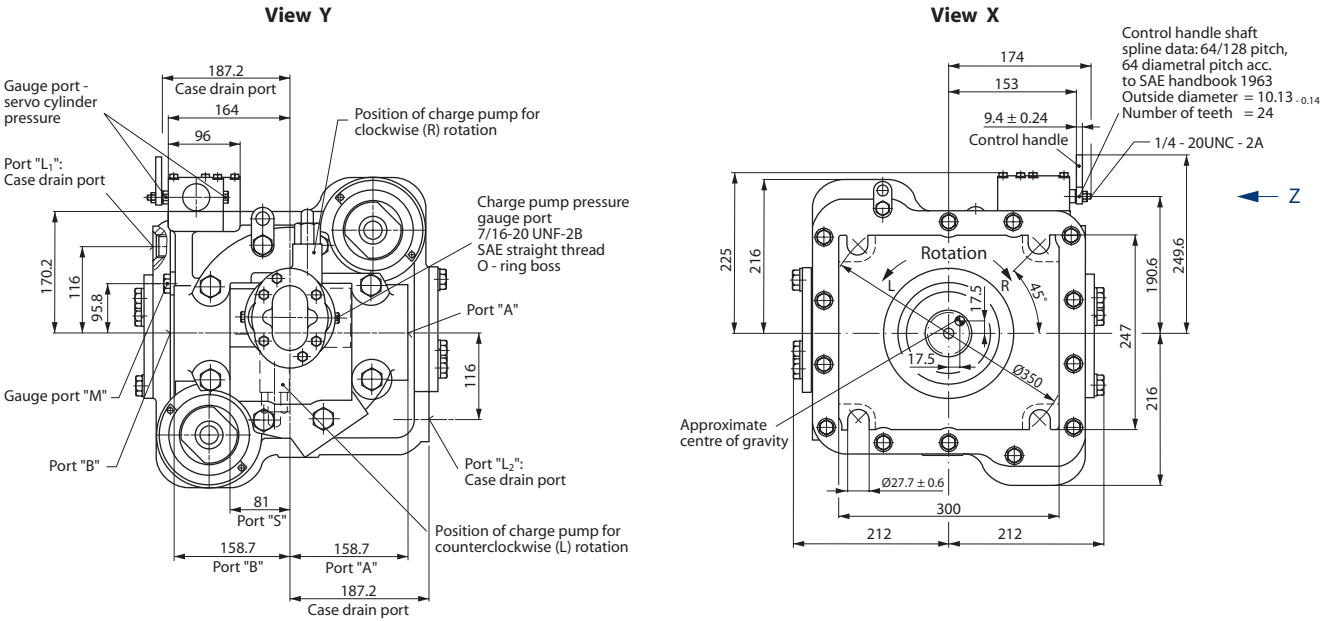

P005 111E

Frame size	Port A and B	Port L ₁ and L ₂	Port S	Port M
334	SAE flange, size 1 1/2 SAE split flange boss 6000 psi 4 threads 5/8-11 UNC-2B 35 deep	1 7/8-12 UNF-2B SAE straight thread O-ring boss	SAE flange, size 1 1/4 SAE split flange boss 3000 psi 4 threads 7/16-14 UNC-2B 28 deep	7/16-20 UNF-2B SAE straight thread O-ring boss

**PUMP CONFIGURATION
 AA 010, DISPLACEMENT
 CONTROL VML 1**

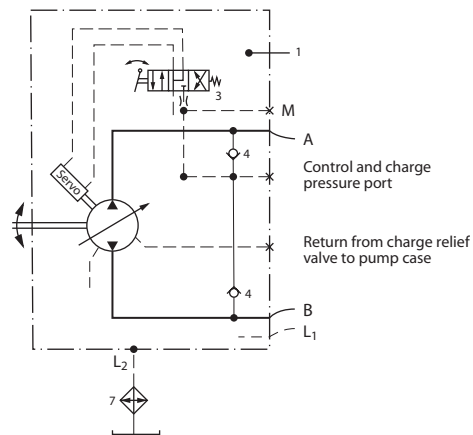

Designation:

- 1 = Variable Displacement pump
- 3 = Servo control valve
- 4 = Charge check valve
- 7 = Heat exchanger

Ports:

- A, B = Main pressure ports (working loop)
- S = Suction port - charge pump
- L1, L2 = Drain ports
- M = Gauge port - charge pressure

P000 058E

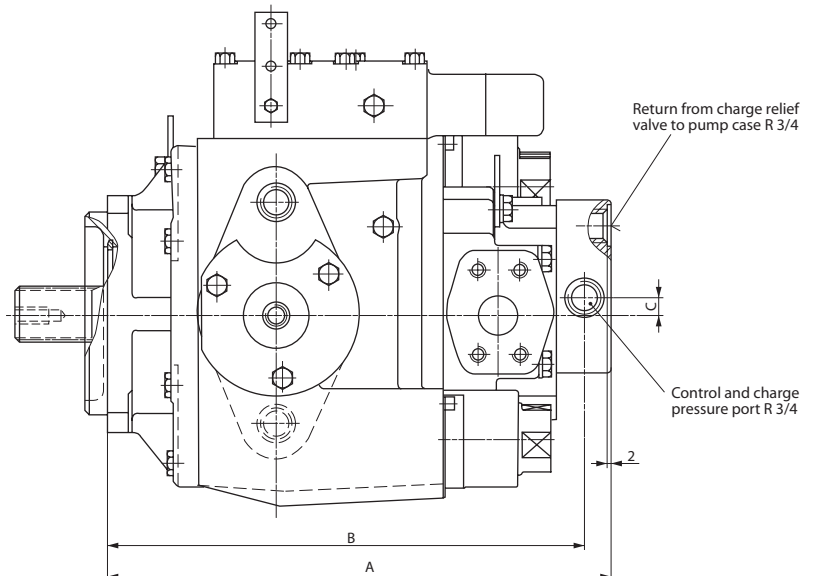
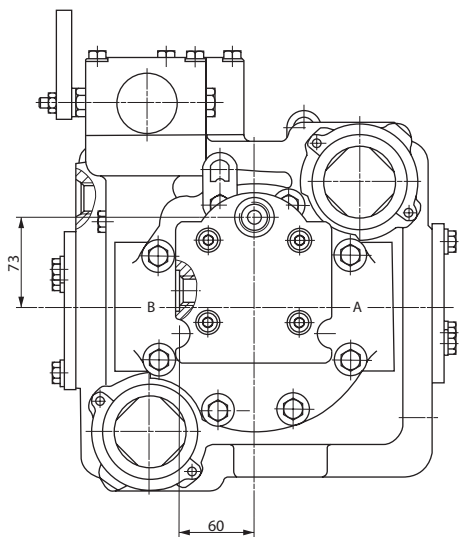

P000 010E

Dimensions

Frame size	A mm [in]	B mm [in]	C mm [in]	Weight kg [lb]
334	546 [21.496]	520 [20.472]	21 [0.827]	264.5 [583]

OUR PRODUCTS

Hydrostatic transmissions
Hydraulic power steering
Electric power steering
Electrohydraulic power steering
Closed and open circuit axial piston pumps and motors
Gear pumps and motors
Bent axis motors
Orbital motors
Transit mixer drives
Planetary compact gears
Proportional valves
Directional spool valves
Cartridge valves
Hydraulic integrated circuits
Hydrostatic transaxles
Integrated systems
Fan drive systems
Electrohydraulics
Microcontrollers and software
Electric motors and inverters
Joysticks and control handles
Displays
Sensors

Sauer-Danfoss Mobile Power and Control Systems – Market Leaders Worldwide

Sauer-Danfoss is a comprehensive supplier providing complete systems to the global mobile market.

Sauer-Danfoss serves markets such as agriculture, construction, road building, material handling, municipal, forestry, turf care, and many others.

We offer our customers optimum solutions for their needs and develop new products and systems in close cooperation and partnership with them.

Sauer-Danfoss specializes in integrating a full range of system components to provide vehicle designers with the most advanced total system design.

Sauer-Danfoss provides comprehensive worldwide service for its products through an extensive network of Authorized Service Centers strategically located in all parts of the world.

Sauer-Danfoss (US) Company
2800 East 13th Street
Ames, IA 50010, USA
Phone: +1 515 239-6000, Fax: +1 515 239 6618

Sauer-Danfoss (Neumünster) GmbH & Co. OHG
Postfach 2460, D-24531 Neumünster
Krokamp 35, D-24539 Neumünster, Germany
Phone: +49 4321 871-0, Fax: +49 4321 871 122

Sauer-Danfoss (Nordborg) A/S
DK-6430 Nordborg, Denmark
Phone: +45 7488 4444, Fax: +45 7488 4400